

## Triplex Plungerpumpe K 10000

P 15-1

### Triplex Plunger Pump

01.02.2008

- Förderstromangaben mit 100% volumetrischem Wirkungsgrad und 20°C Umgebungstemperatur
- Mindestvordrücke je nach Fördermedium
- Mindestdrehzahl je nach Stangenkraft
- Getriebe mit Zwangsschmierung (> 110 kw mit Ölkühler)
- Standard Getriebeuntersetzungen  
i = 3,00 - 3,14 - 3,39 - 3,76 - 4,13 - 4,50 - 4,93
- Auch nach API 674 lieferbar
- Sondermedien wie Seewasser, Glykol, Methanol, Öle, etc. auf Anfrage

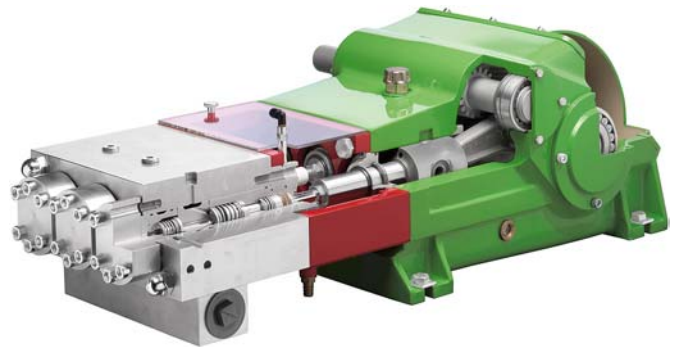

- Flow rate is based on 100% volumetric efficiency and 20°C ambient temperature
- min. inlet pressure depending on fluid medium
- min. rpm depending on rod loading
- Gear with force-fed lubrication (> 110 kw with oil cooler)
- Standard gear ratios  
i = 3,00 - 3,14 - 3,39 - 3,76 - 4,13 - 4,50 - 4,93
- Also available to API 674
- Special medium such as sea water, glycol, methanol, oils, etc. on request

$n_{nom} = 475 \text{ 1/min}$		p max. bar @ kW				Kopftyp / Headtype		
Typ / Type	l/min	75 kW	90 kW	110 kW	130 kW	A	M	MC
K 10012	15	2600	3120	3500	----	x		
K 10014	21	1900	2270	2780	3300	x		
K 10016	27	1470	1770	2160	2500	x		
K 10018	34	1170	1405	1715	2050	x		
K 10020	43	925	1110	1360	1630	x		
K 10022	51	775	935	1140	1370	x		
K 10024	61	650	780	955	1150	x		
K 10026	72	550	665	810	975	x		
K 10028	83	480	575	700	845	x		
K 10030	96	415	500	605	730	x		
K 10032	109	365	440	535	645	x		
K 10036	138	290	345	420	510		x	
K 10040	170	235	280	345	415		x	
K 10045	215	185	220	270	330		x	x
K 10050	266	150	180	220	265		x	x
K 10055	321	125	150	180	220		x	x
K 10060	383	105	125	150	185		x	x
K 10065	449	90	105	130	160			x

# Maßzeichnung K 10000

Dimension drawing

385 kg

P 15-2

01.02.2008

**Hochdruckkopf A**  
High Pressure Head A

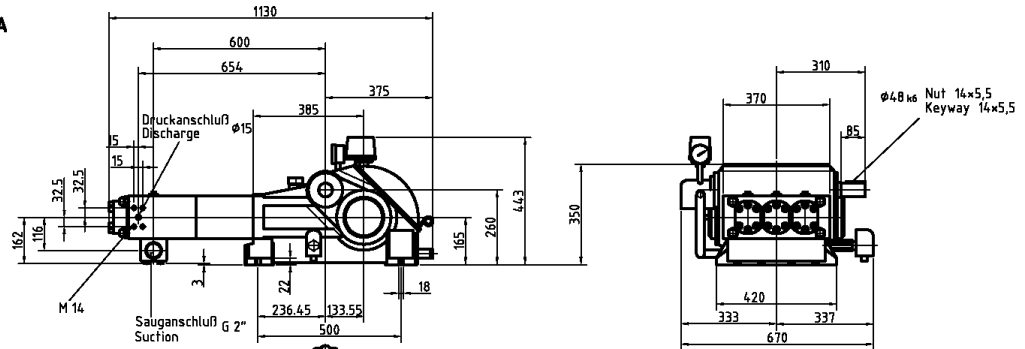

**Hochdruckkopf A**  
High Pressure Head A  
≥ 2000 bar

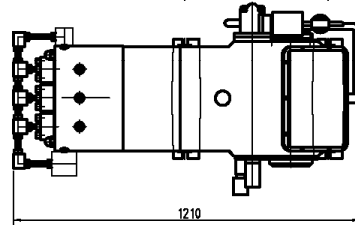

**Kompaktkopf M**  
Compact Head M

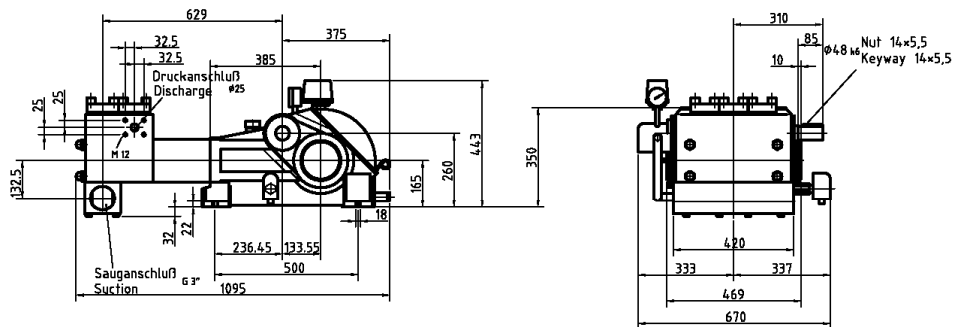

**Niederdruckkopf MC**  
Compact Head (Low Pressure) MC

